



TX/Communications Canada Inc.

Infinity TX-2400S

Digital Switching System

General Description

Date: May 2002
TX-2400S-Sys-GD-001

The Information contained is subject to change without notice.
No part of this document may be reproduced or disturbed in any form or by any means, or stored in a database or retrieval system, without the prior written permission of the TX/Communications Canada Inc.

Introduction

This section provides general information about the capabilities, design, and the operation of the **Infinity TX-2400S** PABX. To know more about the supplementary services and interfaces of **TX-2400S**, refer to:

- Appendix A for the list of features
- Appendix B for System Peripherals (ISDN Attendant Consoles, ISDN Feature Set)
- Appendix C for System built in **IVM (Integrated Voice Mail)**
- Appendix D for ACD (Automatic Call Distribution) feature

TX-2400S is a very modern and extremely low profile PABX for private application. The basic system is a digital switching exchange, providing connection of pulse code modulation (PCM) voice and data paths between ports of various types, under centralized stored program control.

TX-2400S can provide up to 120 digital ports/ 96 Analog ports or a combination of Digital and Analog ports up to 128 ports.

Up to 128 Erlang traffic can be handled by a fully loaded system resulting in 4,600 BHCA @ 100 Sec. Call Average Holding Time.

The **TX-2400S** basic system assembly includes one **MCU (Main Control Unit)** as the system main controller, and one **PSU (Power Supply Unit)** which supplies a ring signal and different voltages to the system.

Below is the system simple block diagram and brief specification of different cards:

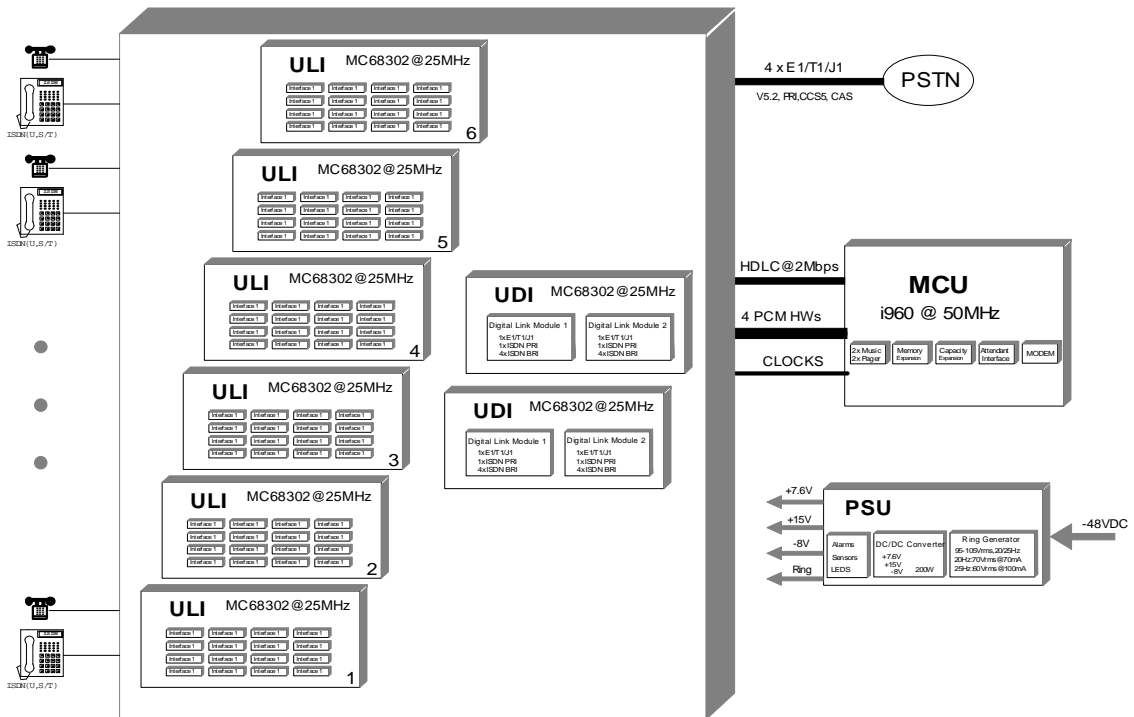

1. MCU:

The MCU is equipped with a 32bits RISC processor (Intel i960) operating @ 16MHz, a proprietary 128x128

Non-blocking time-space switching matrix, attendant console interface, built-in modem and expansion PLL card. Other specifications are as follows:

- PCM Switching, Mixing & Attenuation is compatible with the TX-2400M and TX-2400L systems
- HDLC communications between MCU and Interface cards
- Tone Generation: DTMF and Progress Tones
- Attendant Console I/F
- 16 Channels Tone Detector (DTMF & Dial Tone)
- Two external Music source inputs
- Two external paging outputs
- An built in MODEM for remote access
- Two RS232 data links for SMDR printer and service terminal
- Real Time Clock
- Battery Backup/Flash Main Memory
- Extensive Self Test capability
- Intel i960jx RISC processor
- Interface connectors to optional modules
- ACIA links
- Optional features:
 - System memory expansion
 - 32 channels Tone detector
 - Phase Lock Loop clock module for synchronizing the system clocks to incoming Digital trunks (E1/T1, ISDN BRI and PRI) with automatic reference switch over
 - Power Control Module supports 2 PFT circuits
 - Relay Control Module supports 4 sets of relay outputs for common audible and backup Ring generator
 - Remote Sense Module can sense 4 external relay closure for application like security sensor, doorbell
 - Message Recording module for voice announcements
 - DSP Module for 32 way conference, tone signaling support
 - Cabinet Expansion Module provides signal interfaces to the expansion cabinet and additional PCM capacity
 - Wall Mount Kit to mount the cabinet on a wall
 - Expansion Cabinet

2. PSU:

The PSU is a single PCB with the combination of DC/DC Converter, Ring generator and Alarm Monitoring circuitry.

The DC/DC Converter is a 200W isolated switching power supply that generates regulated +7.6V, +15V, -8V DC power from -48VDC input.

The Ring Generator supplies 20Hz/25Hz ringing voltage from -48VDC input. The shelf protection voltage circuit uses the ringing voltage to generate the shelf' most positive and most negative voltages for protection biasing.

Four signals are generated by the Alarm Monitoring Circuitry, LLA (Low voltage Limit Alarm), HLA (High voltage Limit Alarm), OVP (Over Voltage Protection) and OTS (Over Temperature Sense).

The out put voltage (+7.6VDC) is monitored for both upper and lower limit of 5%. Once the voltage drops or raises by 5%, the LLA or HLA is generated receptively. When the +7.6VDC output voltage increases more than 12% (i.e. about 8.5VDC), the OVP is generated and the PSU is shut down.

If the free air temperature around the PSU raises above 57°C, the OTS is generated.

The ringing voltage is monitored and alarm is raised if the voltage falls below 55Vrms for longer than 500mSec.

3. Interface Cards:

Two universal cards are employed by the system to accommodate all different Digital and Analog applications, **ULI** and **UDI**:

3.1 The ULI (Universal Line Interface) is equipped with a processor to control all types of Analog ports, such as Ordinary Subscriber Lines, Metering Subscriber Lines, Coin Box, E&M, DID, DOD and CO Trunks with all the standard signaling. Each ULI accommodates 16 analog ports of each type.

Specifications:

- a. MC68302 Microprocessor operating at 25 MHz clock.
- b. 4 MB system Flash program memory.
- c. 1 MB system RAM.
- d. Two HDLC channels at 2Mbps (1 active and 1 backup).
- e. On Board DSP for Tone detection and generation.
- f. On Board 256x256 Cross Point switch.
- g. Equipped with auxiliary Port for On-hook FSK transmission of Message Waiting, Calling Name and Number display, PCM data analysis for a thorough parametric transmission test of the voice path and for running diagnostics to permit trouble shouting in the field.
- h. 32 Analog Ports with full service capability.
- i. Visual Waiting.

The ULI card is designed to meet or exceed CCITT, Bellcore LSSGR, EIA-464, ETSI ETS300-001, FCC part 68, DOC CS-03, UL1459, CSA C22.2 # 225-M90 specifications and recommendations for both in premise and off premise use.

3.2 The **UDI (Universal Digital Interface)** is also a processor equipped card to control all types of Digital ports such as E1, T1, J1, ISDN-BRI, ISDN-PRI, with all types of signaling such as CCS#5, V5.2, CAS, R1, R2.

It could be directly connected to Fiber Optic cables by using an optional Back card.

Each UDI card can accommodate two Link Modules, each of which can interface to:

- One ISDN-PRI,
- One 2Mbps Link,
- Four ISDN-BRI, U Interface (2B1Q)
- Fiber Optic
- X.25 Packet Switching for B channel, HDLC or other
- Voice Messaging node
- Extra Memory Module
- UDI Tester Module

Specifications:

- a. MC68302 Microprocessor operating at 25 MHz.
- b. 2 MB system Flash/ROM program memory.
- c. 2 MB system RAM with Back-up battery.
- d. Two HDLC channels running @ 2Mbps for inter-system communication (1+1).
- e. On Board two DSP for Tone Processing/Conversion.
- f. On Board two 256x256 Cross Points for time slot based information switching.
- g. Equipped with powerful high density FPGAs and CPLDs.
- h. On Board 256 Kbytes SRAM for storing different tones PCM samples.
- i. 2 x E1/T1/J1 links with full service capability.
- j. 2 x 4 ISDN 2B1Q U interface service capability.

The **TX-2400S** system is available with a standard software package that is field configurable for various applications.

System Specifications:

- PCM-TDM Technique
- **SPC** (Stored Program Control)
- ITU-T, *Bellcore*, ETSI UL1459, FCC, UL and CSA Conformity
- HW/SW fully modular and scalable
- **128 x 128** non-blocking, full available Switching Network
- Four Cards Variety (MCU, PSU, ULI, UDI)
- Inter-System Communications on 2Mbps HDLC Link
- Intelligence : On MCU and Universal (Analog/Digital Interface) Cards
- Customized Application Capability due to the use of FPGA, CPLD, DSP on all Cards
- Alarm display of:
 - Temperature sensor
 - Thermal shutdown
- Capacity : 128 Ports expandable to 256 Ports with expansion shelf
- Caller ID feature for all Lines complies with ETSI and Bellcore
- Message Waiting feature for all Lines complies with ETSI and Bellcore
- Microprocessors : 16, 32 bits wide powerful Processors
 - @ [25MHz (**MC68302**, IMP), 16MHz (**i960**, **RISC**)]
- 1 Erlang traffic/Port, Tone (DTMF, R1, R2) Processing Capability
- BHCA: 4,600 @100 Sec. Average Holding Time

- Interfaces :
Analog: All types of Analog Line and Trunk Modules
Digital: E1, T1, J1, ISDN-PRI, and ISDN-BRI
Transmission Rate: E1
Network: 10BaseT Ethernet Connection Interface
- Signaling : Loop Start (600/900 Ohm), Ground Start (600/900 Ohm),
Battery Reversal, DTMF, R1, R2, CAS, CCS#5, ISDN-PRI, V5.2
- **X Signaling to Y Signaling Converter/Translator**
- Highly reliable common control equipment with extensive fault detection and recovery capabilities and component level troubleshooting
- Built in Remote maintenance facility
- Multiple ISDN Operators Console operation
- Blind ISDN Operator Console
- Voice recording capability on all consoles
- Built in directory
- Management monitoring and control features
- Flexible Numbering Plan
- 2 Hours of Digital Voice intercept Messaging per shelf
- Two external paging outputs
- Two external Music source inputs
- 8000 Seconds Voice Messaging/Announcement, up to 511 messages, 16 Sec. Each
- 100 Hours, 32 Channels Voice mail Capability

- Automatic Voice recording for malicious calls
- 16 way conference call
- Interactive Voice Response (I.V.R)
- Three Way Conference Call for all lines with injection of any separate message to each of the parties on the conference call without any interruption of live calls.
- 32 Channel ADPCM Voice Compression/Decompression on **IVM** (Integrated Voice Mail Card
- Application : PABX, Small Transit Switch, Intermediate Gateway Switch, Signaling converter
- Power Consumption : Less than 1W/Port @ High traffic loads
- Built in 9600 Modem on MCU
- Built in RS232 serial port on all ULI and UDI cards for future applications
- Weight: 30 Kg (Fully loaded)
- Dimension:
 - Height: 42 cm
 - Width: 36 cm
 - Depth: 40 cm

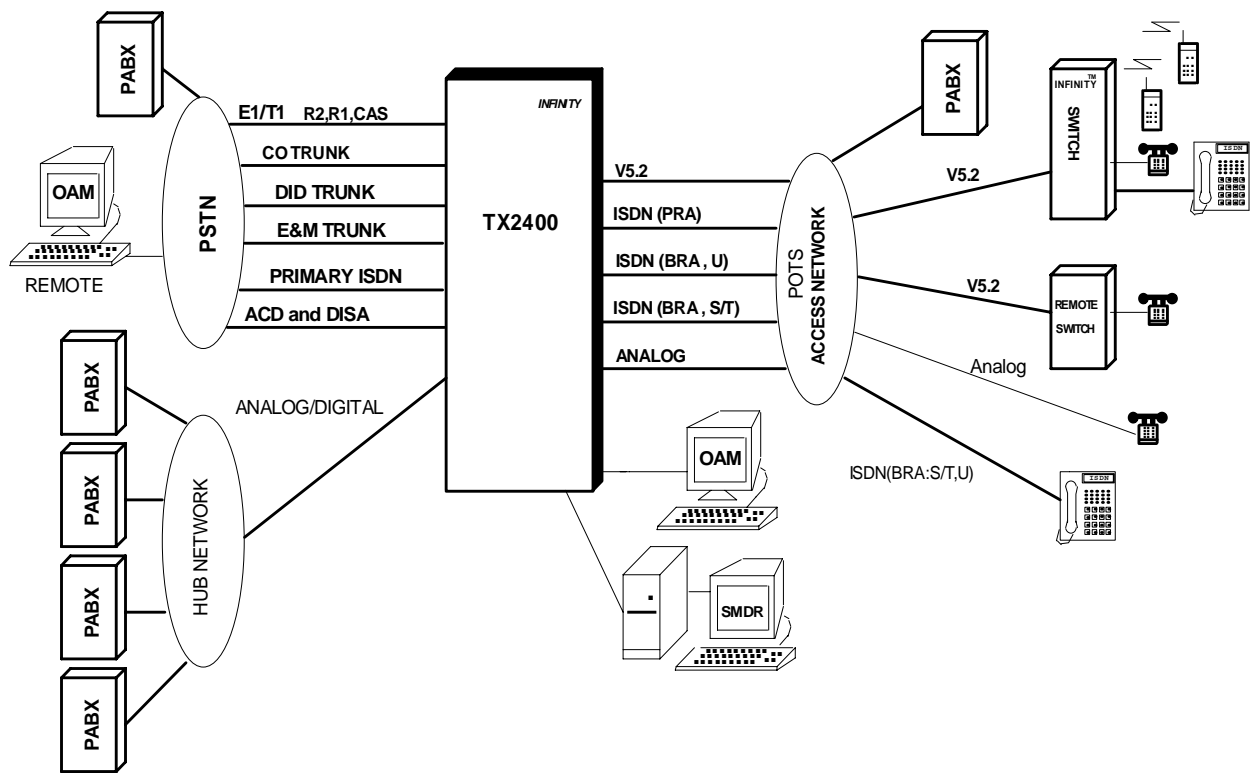
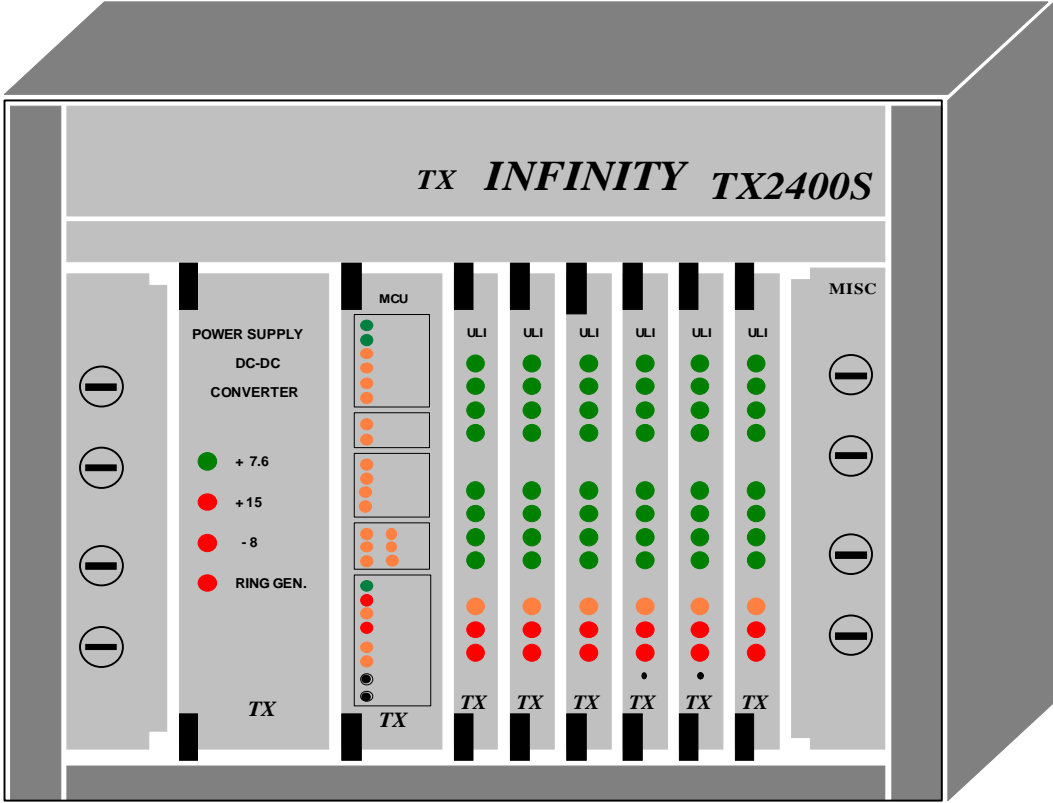

Fig.1: TX-2400S Application Diagram



INFINITY TX-2400S FRONT VIEW

Application: PABX with Analog CO trunk connection.

Capacity Example: 96 Analog ports (Line and Trunk)

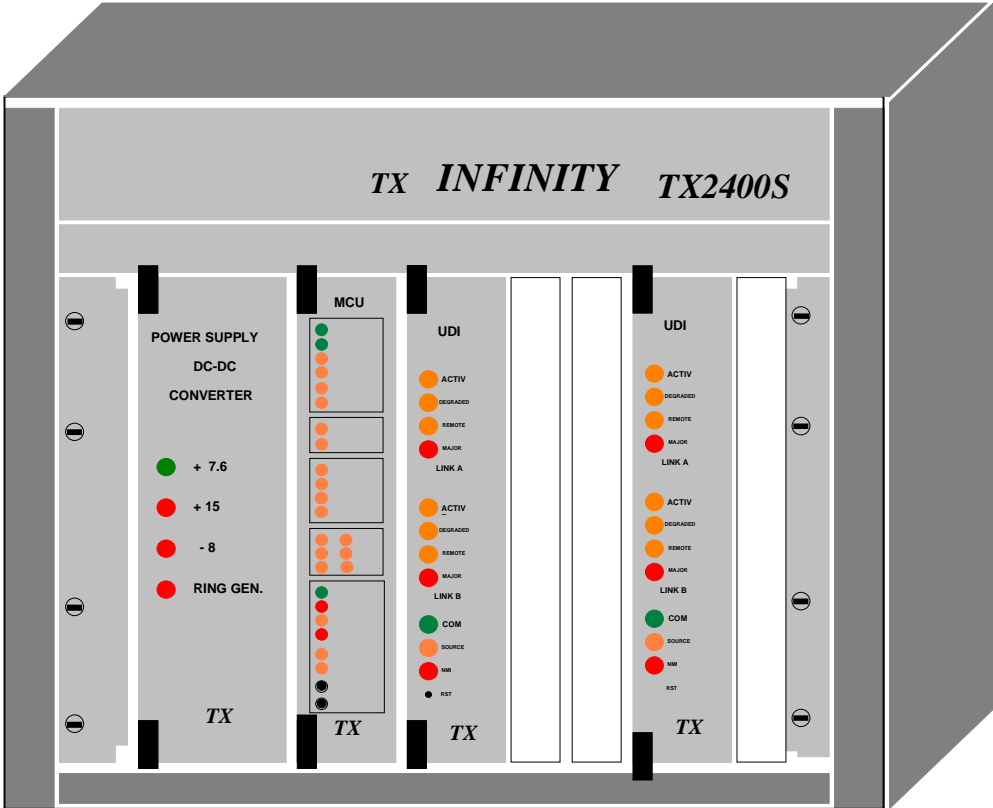

Application: Small Transit switch.

Capacity Example: 120 E1/T1 Transit Switch

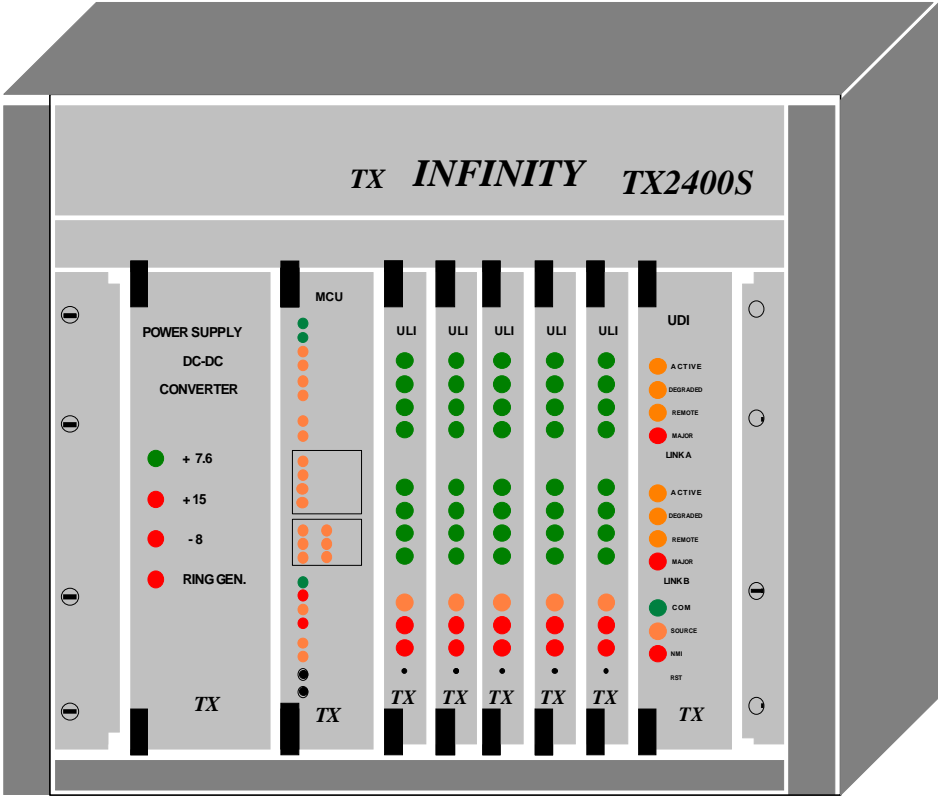

Application: PABX with E1/T1 Digital trunk connection.

Capacity Example: 30 E1/T1 and 80 Analog ports (Line and Trunk)

Administration and Maintenance

Introduction:

The **TX-2400S** switching system supports more than 200 commands for administering and maintaining the system. Commands are entered interactively on a service terminal, which can be local, or at remote location connected to the switch through a built in modem.

Various commands exist to change configuration data for the system, subscribers, attendants and trunks. The **TX-2400S** switch also offers an extensive range of commands to trace faults on the system, display current status of calls and examine traffic statistics.

THE SERVICE TERMINAL

The commands to the system are entered on the service terminal. Any responses resulting from the commands are displayed on the Service Terminal. Service terminals can be simple display units or Personal Computers running any serial communication program. One of these programs maybe **TX-2400S'** own TXLINK. The advantage of using TXLINK is that configuration files can be saved and reloaded from the computer's memory.

TERMINAL TYPES

Any data terminal device (including hard copy terminals) that meets the following requirements can be used as a Service Terminal:

- Display/print ASCII Character Set
- Generate all uppercase characters (CAPS LOCK capability)
- RS-232C Serial Interface

CONNECTIONS

The Service Terminal can be located either on the same premises as the **TX-2400S** switch, or at a remote location through the use of modems. Local connection of the Service Terminal to the **TX-2400S** is via a serial port on the MCC port located on the back panel of the cabinet. Remote connection is via one of the 2 built in Modem ports on the back panel. To communicate with one another the communications setting of the **TX-2400S**'s serial port and the Service Terminal must be identically configured. The default settings of the Service Processor are as follows:

- 9600 bits per second transmission speed
- 8 data bits and no parity
- 1 stop bits

For more information about connecting the Service Terminal to the **TX-2400S** see the appropriate **TX-2400S** Installation and Maintenance Manual and the terminal's documentation.

TXLINK

TX Link is a proprietary software program that allows an IBM Personal Computer (PC) or compatible device to operate as a Service Terminal. Unlike a "dumb" terminal, using a PC permits the storage of the **TX-2400S**'s configuration data on disk. In the event of a long-term power failure the configuration data can be reloaded from the PC to the **TX-2400S**. The information and instructions provided in this document apply regardless of whether a dumb terminal or a PC is being used as a Service Terminal. See the TX Link User's Guide or System programming Guide for more information.

USING TWO SERVICE TERMINALS

When two Service Terminals are connected to the **TX-2400S** (one to the MCC serial port and the other to the Modem port) the first terminal to log on will have use of the Service Processor. Any attempt to access the Service Processor while it is in use will result in a "**COMMAND IN PROGRESS**" message. Access to the Service Processor can be gained when the terminal that is currently using the Service Processor logs off, or when the command in progress has been processed. In either case, to get the attention of the Service Processor, see the STUG manual. When the Command Line prompt (<) appears enter a command must be entered before preset time out, otherwise the other terminal will regain control of the Service Processor.

SERVICE TERMINAL ERROR CODES

A number of hexadecimal error codes may appear on the screen during the operation of the Service Terminal. These error codes are produced for a variety of reasons as explained in the Service Terminal Error Codes Table located in Appendix A of this guide.

COMMAND LISTING BY FUNCTION

Some system components or features such as Least Cost Routing are programmed using two or more commands. For each significant component or feature, all of the commands required to make the component or feature operational are listed on the STUG manual.

DEFAULT CONFIGURATION

When powered up for the first time the **TX-2400S** automatically produces a configuration based on a five digit numbering plan and a scan of the hardware installed. The type of hardware in each slot will be reconfigured to the installed hardware. For each component or feature for which data can be altered, the default programming is stated. Among the more significant default conditions are:

- Equipment Shelves with ISDN Feature Sets (IFS) installed when the **TX-2400S** is first powered up, are configured with CLS option 4 (i.e., Digiphone Broadcast enabled.)
- All lines that are associated with IFS are programmed as type S.
- All equipped ports are programmed as type T for analog ports (ULI) and S for digital ports (UDI).
- All subscribers are assigned to Station Class of Service 0 which allows unrestricted access for outgoing calls.
- The first audited trunk (loop or ground start) determines the trunk type of route 0. All subsequent trunks of the same type are assigned to this route.

Appendix A

TX-2400S

List of Features

1. SYSTEM FEATURES

Account Code Capability
Area/Office Code Exceptions
Attendant Console
Attendant Transfer - All Calls
Authorization Codes
Auto Attendant Operation
Automatic Number Identification
Automatic Station Release with Howler
Camp-on Tone Suppression
Class of Service (COS)
Code Call Access
Combination Trunks
Common Control Switching Arrangement (CCSA)
Configurable CO Numbering Plan
Console-less Operation
Department Call Control
Diagnostic Circuitry
Dictation Access and Control
Digiphone/ISDN Feature Set
Digital Trunk - CEPT
Digital Trunk - R2 Signaling
Direct Department Calling
Direct-in Lines
Direct Inward Dialing (DID)
Direct Inward System Access (DISA)
Direct Outward Dialing (DOD)
DTMF System Out-pulsing
Executive Override
Facilities Administration and Control
Flash - CO and Switch/Centrex
Flexible Intercept
Flexible Directory Numbers
Flexible Station Programming - Circuits
Flexible Station Programming - Features
Fully Restricted Stations
Hands free Stations
Hotline Stations
Hunt Groups
ISDN Feature Set - Data Ports
Key System Operation

Least Cost Routing (LCR)
Linked Numbering with a Foreign Switch
Maintenance Facility
Message Announcement Module

Meter Pulses - Generation
Miscellaneous Trunk Restriction
Multi-Console Operation
Multiple Listed Directory Numbers
Multi-Party Conference
Multi-tenant
Multiple Trunk Groups
Music on Hold
Name Directory Dialing
Night Service - Department
Night Service - Station
Night Service - System
Off-Premises Extensions (OPX)
Originating Restriction
Outward Restriction
Password Levels
Power Fail Transfer
Power Failure Restart - EPROM
Processor Changes - Administration Panel
Processor Changes - Remote Access
Programmable Station Ringing Assignments
Programmable Time Outs
Radio Paging Access
Remote Maintenance Facility
Remote System Alarm Access
Service Terminal Trace Commands
Speed Dialing Restrictions
Station DTMF to Dial Pulse Conversion
Station Message Detail Recording (SMDR)
Station Transfer Security
Supervised Station Release
Tandem Trunking
Tariffs
Tie Trunk Access
Traffic Measurement
Trunk Answer from any Station (TAFAS)
Uniform Call Distribution (UCD)
Voice Messaging
Voice Paging - Phone Speakers

2. HOTEL/MOTEL/HOSPITAL FEATURES

General Comments
Attendant Hotel/Motel Console
Automatic Controlled Station-to-Station Restriction
Automatic Wakeup
Do Not Disturb
Electronic Message Registration
Guest Phone
In/Out Status
Intercept Treatment - Attendant Night Barring
Manual Originating Line Service (MOLS)
Message Waiting
Phone Status Display - Attendant
Restrictive Station Control
Room Number Correlation
Room Status - Attendant
Single Digit Dialing for Services
Speed Calling for Services
Supervised Station Release
Termination Restriction - Attendant
Maintenance Services
Maintenance Display/Status

3. NETWORK FEATURE

Automatic Overflow to Direct Distance Dialing (DDD)
Call Queuing
Centralized Attendant Service (CAS)
Customer Administration Center - Network
Electronic Tandem Switching Service
In-Dialing Through the Main Switch
Inter-Switch Call Transfer
Inter-Switch Coordinated Numbering Plan
Inter-Switch Features and Facilities
Least Cost Routing - Network
Main Switch
Off-Network Optimum Exit Capacity
Satellite Switch
Travelling Class Marks
Tributary Switch

4. ATTENDANT CONSOLE FEATURES

- Alphanumeric Display for Attendant Position
- Attendant Camp-on
- Attendant 15 Way Conference
- Attendant Control of Multi-Party Conference Access
- Attendant Control of Department Calls
- Attendant Control of Trunk Group Access
- Attendant Direct Paging Access
- Attendant Dial Tone Transfer
- Attendant Loop Transfer
- Attendant Overflow Facility
- Attendant Repertory Dialing
- Attendant DTMF Signaling
- Automatic Hold
- Automatic Recall
- Automatic Ring back on Held Call Busy Override
- Attendant Voice Recording Capability
- Attendant Busy Trunk Override
- Built In Directory No.
- Busy Verification of Stations
- Call Processing Indications
- Call Waiting Display
- Class of Service Display
- Class of Service Restrictions
- Digital Clock
- Emergency Priority Answer
- Incoming Call Identification
- Indication of Major Alarm Type
- Indication of Minor Alarm Type
- Interposition Calling
- Message Waiting
- Multiple Listed Directory Number - Attendant
- One-Way Automatic Splitting
- Serial Call
- Station Busy Lamp
- Station Number Display
- Switched Loop Operation
- Trunk Group Busy Lamp
- Trunk Number Display
- Trunk-to-Trunk Connections
- Trunk Verification by Attendant
- Voice Paging Access - "Meet-Me" With Trunk
- Volume Control - Console Signal

5. STATION FEATURES

Add-on Conference
Answer Hold (Touch-tone and Rotary Phones Only)
Automatic Call Back (On-hook camp-on)
Call Forwarding
Call Hold
Call Hold Reminder
Call Park
Call Transfer
Call Transfer with Camp-On
Camp-On
Consultation Hold - All Calls
Conference Mode Display
Data Privacy
Dial Call Pickup
Directed Call Pickup
Direct Station Selection (DSS)
Direct Trunk Access
Direct Trunk Group Selection
Discriminating Ringing
Do Not Disturb (DND)
Emergency Dialing
Executive Busy Override
Indication of Camp-on to Stations
"Meet Me" Conference
On-Hook Dialing
Recall Dial Tone
Saved Number Redial
Speed Dialing - Individual
Speed Dialing - System
Station Busy Indicators
Station Loop Circuit Terminations
Station Override Security
Station Tone Ringing
Through Dialing
Trunk-to-Trunk Connections - Stations
Unauthorized Phone Use
Voice Paging Access - "Meet Me"
Voice Paging Access - "Meet Me" Page - Call Transfer

Appendix B

TX-2400S

Peripherals

- ISDN Attendant Consoles
- ISDN Feature Set (IFS)

ISDN Attendant Consoles:

The Attendant Console is a desktop unit that functions as the main answering position for the INFINITY system.

Attendants can process calls quickly and professionally, even during heavy call traffic, with all the information required right at their fingertips.

Clearly legible LCD's and easily operated keys increase efficiency. An external Busy Lamp Field (BLF) is available on request.

There are four Attendant Console models available. The choice of model will depend on your requirements.

Basic Attendant Console:

Although the Basic ISDN Attendant Console looks similar to the INFINITY Executive Feature Set (IFS), it provides additional capabilities essential to Attendant operation. Three different types of LCD screens provide Night Service, Call Processing and Attendant Self-Test. A 20 character by two-line display provides call-processing information while the keyboard layout encompasses most of the Standard ISDN Attendant Console keys, including 10 source keys. This basic model is equipped with a microphone and speaker for hands free operation and with an optional data port for PC connection.

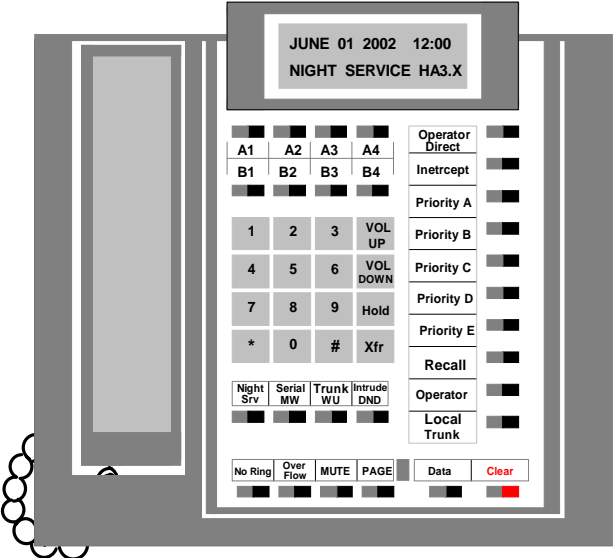

Standard Attendant Console:

The standard ISDN Attendant Console provides features in addition to functions provided by the basic Console, such as answering trunk calls and providing local user assistance. The standard Console uses a 4-line by 40-character LCD display and 11 source keys for call processing information. Optional Audio Voice Recording is also available. It has a 1 x 8 character display for indicating the source Key queue lengths.

An internal directory provides over 1500 subscriber lines with name identification. Five different screens provide Night Service, Call Processing, Directory assistance, Station Status Indicator and Test Mode.

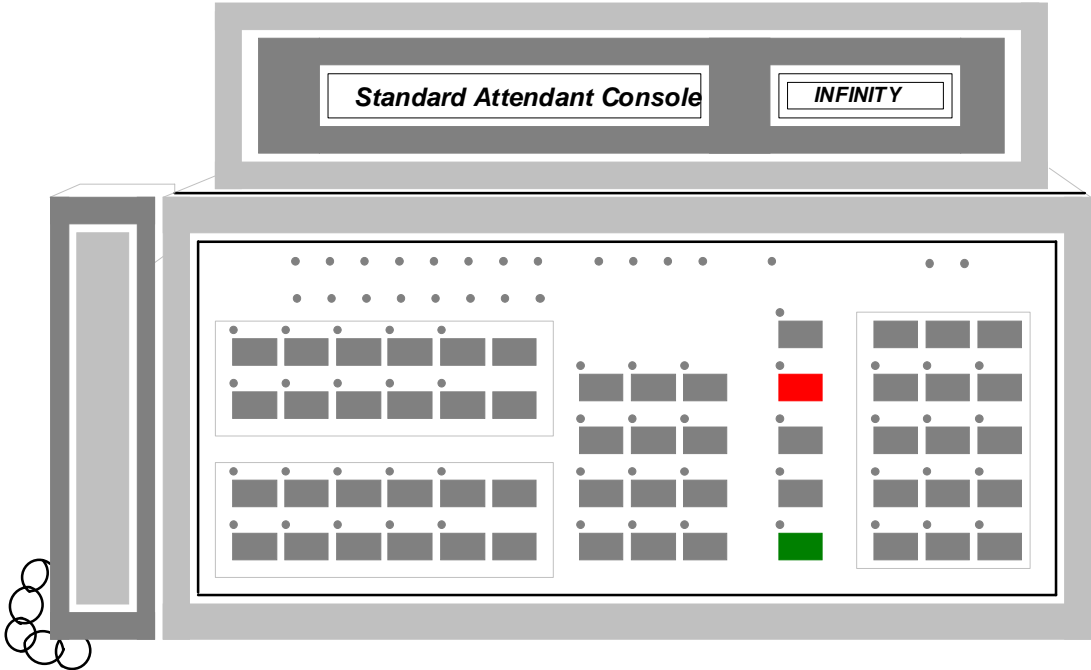

Enhanced Attendant Console:

The Enhanced Attendant Console allows access to all the ISDN services offered with the INFINITY switch. This console, in connection with your PC, will provide access to any data base inside or outside of the system. It is equipped with a data port for PC connection, full 2B+D capability and an internal directory of over 1500 subscriber lines with name, department and status. New features include a larger LCD with CRT option and a configurable display setup. Ease of operation is ensured by a Station Status Display of selected subscriber lines and a display of the number of calls queued up in the source keys. Function keys reduce keystrokes. Operation equipment includes a full size IBM compatible Keyboard interface and a multi message voice-recording module. In addition to all these advancements, the Enhanced ISDN Console supports visually impaired operators with Blind Console operation and Hands Free operation.

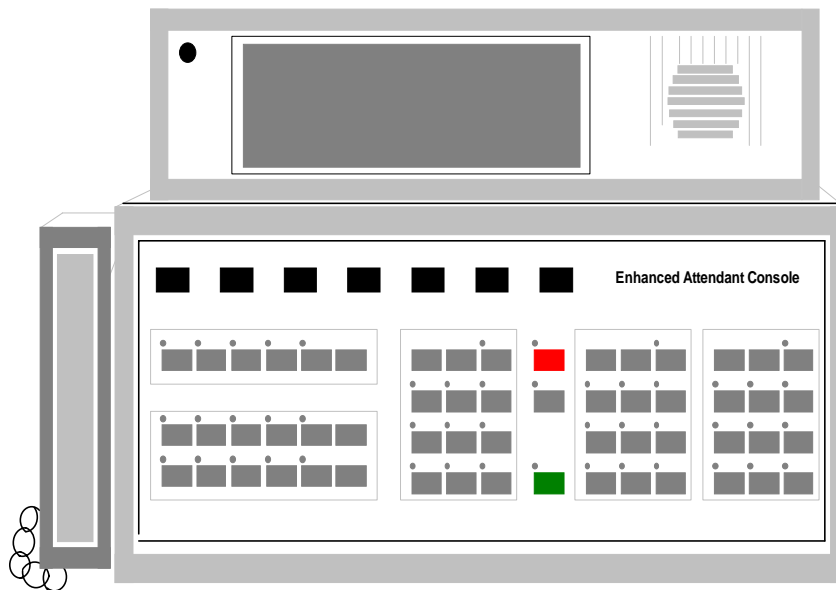

Dispatch Console:

The Dispatch Console has similar capabilities to the Executive ISDN Feature Set with 55 programmable keys, for BLF or DSS. The Dispatch Console is equipped with a 4x40 LCD display and 1x8 LCD display. It is capable of audio recording output for recording devices and offers external ringer control.

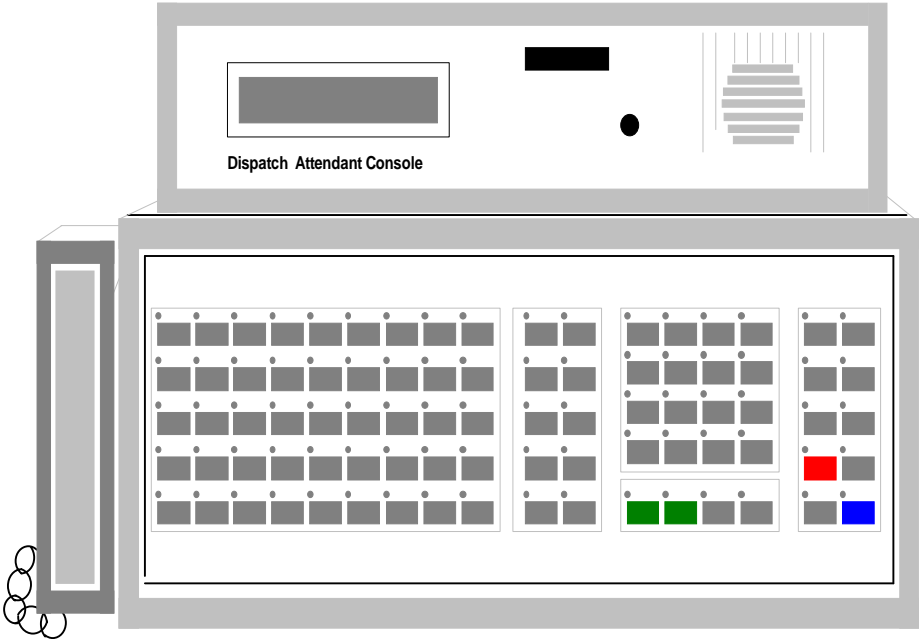

ISDN Feature Set (IFS):

The Infinity family of switches provides over sixty features and facilities that, without an IFS, require a special access code. With an IFS, feature or facility selection is made by the push of a button. These sets can be customized by on-site programming to provide each user with the group of features judged most useful by the user.

Each feature button is multi-layered and can be assigned with a personal speed dial number in addition to any other feature. Flexibility and extreme ease of use make IFS ideal for executive, secretarial or special answering position stations.

For the secretary program, features include call signaling, call pick-up, busy lamps and single keystroke calling of pre-selected stations.

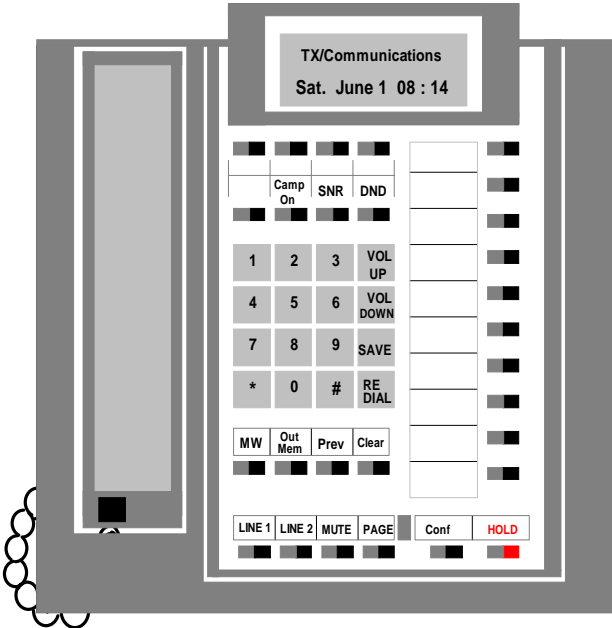

For special answerers there is a program hunting group features to provide message center, overflow answerer or call distribution and other features to streamline call answering and processing.

The **R** Interface DATA Port is compatible with the Hayes Smart Modem and provides RS-232C connection for up to 38.4Kbits and adaptation for V.110 bit rate.

Below, there is a partial list of the features offered:

Features:

- Add-on conference
- Automatic Call Back
- Automatic DSS Intercom
- Automatic Ringback on Held Key
- Background Music
- Call Forwarding-Chain
- Call Forwarding-External
- Call Forwarding-Internal
- Call Forwarding-Busy Line-Internal
- Call Forwarding-Destination Display
- Call Forwarding-Don't Answer-External
- Call Forwarding-Don't Answer-Internal
- Call Forwarding-Preset
- Call Forwarding-Stored
- Call Hold
- Call Hold-Automatic Call Back
- Call Park
- Caller ID Line
- Camp-On
- Common Audible Ringing
- Consultation Hold-All Calls
- Conference Mode Display
- Data Privacy
- Delay Hotline
- Dial Access to Attendant
- Direct Call Pickup
- Do Not Disturb
- Emergency Dialing
- Executive Busy Override
- Flexible Station Controlled Conference
- Indication of Camp-on to Station
- Individual Transfer-All Calls
- Magneto Phone Monitoring

- Meet-Me Conference
- Multiple Discrimination Ringing
- On-Hook Dialing
- Party Line
- Prime Line Preference
- Recall Dial Tone
- Saved Number Redial
- Screened Call Transfer
- Speed Calling-Individual
- Speed Calling-System
- Station Busy Indicators
- Station Call Transfer and Camp-On
- Station Camp-On
- Station Loop Circuit Terminations
- Station Message Waiting
- Station Override Security
- Station Repertory Dialing
- Station Ringer Cutoff
- Station Tone Ringing
- Through Dialing
- Transfer Before Answer-recall
- Trunk-to-Trunk Connections-Stations
- Voice Calling with Hands-free Answer
- Voice Paging Access-Meet-Me
- Voice Paging Access-Meet-Me Page/Call Transfer
- Voice Paging Access Meet-Me with Trunk
- Volume Control-Station

Appendix C

TX-2400S

Integrated Voice Mail

I.V.M

Product Specification

Introduction

The IVM (Integrated Voice Mail) is a menu driven system which can be customized to best suit the needs of your organization.

You can tailor options and menus to your site. Users can also customize personal greetings to communicate their availability daily, weekly or hourly if necessary.

The IVM provides 32 simultaneous connections to the voice mail facilities and because the voice mail for the TX-2400S system is offered on an interface card, no additional subscribers are needed.

The Voice mail provides more than 2000 mailboxes each with 30 minutes of recording time.

IVM can manage communications without a live operator.

The IVM will greet caller with an introduction, ask them to provide the called party's extension or select from options, then transfer the calling party to their requested destination.

The IVM also offers advanced features that will request the calling party for their name for call screening, and can even announce the call over your in-house paging system.

The IVM can also direct the caller to prerecorded messages providing frequently requested information such as directions to your facility, department contacts, product information, etc.

The IVM programming can be done from the system's service terminal. Recording is done easily using a handset and following voice recorded instructions.

Administrative Features:

- Automated Attendant for operator free reception and transfer
- System administration by telephone or Service Terminal
- Remote administration
- Multiple time of day configurations for each class of service, mailbox, menu, or extension
- Call screening and paging options
- Set time and date
- Print or view system administration reports
- Add or delete mail boxes

Users Conveniences

- First time user tutorial for easy set up of mail boxes
- Password protection
- Multiple messaging option including private, urgent, future delivery, and confirmation receipt
- Messages can be played faster, slower, louder, softer or skipped
- Each message can be replayed, saved, deleted, forwarded or replied to with annotation
- Date/time stamp and sending mailbox ID on every message
- Multiple greeting per mailbox, including standard, temporary, busy and time sensitive
- Call screening with calling party name played to mailbox owner who can then accept, reject, or forward the call to another station
- Address by name or mailbox number
- Re-record message reminder
- End of recording warning
- Return to personal operator

IVM (Integrated Voice Mail)

Specifications

The Integrated Voice Mail Card contains two micro-controllers, an i960 and a MC68302. The MC68302 is used for the **TX-2400S** system interface, and the i960 is used for the user interface and storage. There is a 1KB DPR for inter-processor communications. The Voice Mail Card will use double line card slots.

i960 RISC Processor Section

- a. Intel 100 MHz i960JT Processor
- b. 33 MHz external CPU clock.
- c. 2 M bytes system RAM, expandable to 64 M bytes (4 SIMMs).
- d. 2 M bytes system ROM, expandable to 64 M bytes (4 SIMMs).
- e. Real Time Clock.
- f. 10BaseT Ethernet connection.
- g. IDE Hard drive Interface.
- h. Built-in two IDE disk Drive, one of the drive is for Backup.
- i. Up to 64 MB PCMCIA Flash memory card.
- j. One RS232C serial port and modem.

MC68302 Processor Section

- a. Motorola 16MHz MC68302 processor.
- b. 1 MB system RAM and 1 MB system ROM.
- c. One HDLC channel for system side communications.
- d. 8000 seconds voice messaging storing in the PCMCIA flash memory card.
- e. ADSP2184 32 channel DTMF decoder.
- f. 32 channel ADPCM voice compression / de-compression.

The Integrated Voice Mail card (IVM) is designed for the **TX-2400S** systems. The Voice Mail card used in voice applications provides an IDE hard drive for the mass storage of incoming voice messages. The voice message data is directly captured from a PCM Highway and has 32 channels of simultaneously voice mail connections. The voice message is using 2:1 ADPCM compression and stored into the hard drive. The message will be retrieved from the hard drive and play back to the PCM highway.

The other application of the IVM is used for the Voice Recording Device. The voice messages are recorded in PCM format and stored into the PCMCIA Flash Memory card. The IVM supports up to 64 MB of PCMCIA Memory card and therefore provides about 8000 seconds of voice messaging. The voice messaging controller connects into two PCM Highways, it can broadcast any message into the PCM Highways from one to sixty-four time slots, or up to any sixty-four difference messages simultaneously, or in any combinations.

When the IVM is used for both applications at the same time, the limitation will be the voice mail and voice messaging combined together have the resources of maximum of 32 time slots for input and 64 time slots for output.

The IVM can be installed in a single slot card if only the voice messaging function and not the voice mail feature is used.

Design Specification

The **IVM** is using an Intel 100 MHz i960JT RISC processor. The i960 provides a 32-bit linear address space and 32-bit wide internal and external data BUS.

The i960 is mainly used for user interface and mass storage. The major task of the i960 is used to control the 10BaseT Ethernet connection, RS232 interface, modem interface, time keeping and IDE hard disk controlling.

The second processor is a Motorola 16 MHz MC68302 Integrated Multiprotocol Processor. It provides a 24 bit address space and 16 bit wide data BUS.

The MC68302 contains a communication processor to handle the SCC and a MC68000 CPU core.

The MC68302 is used for **TX-2400S** system interface including HDLC communications, DTMF decoding and PCM Highway interface.

A DSP (Digital Signal Processor) is used on the MC68302 side. It is connected as a slave processor to the MC68302. The DSP is used for 32-channel DTMF decoding.

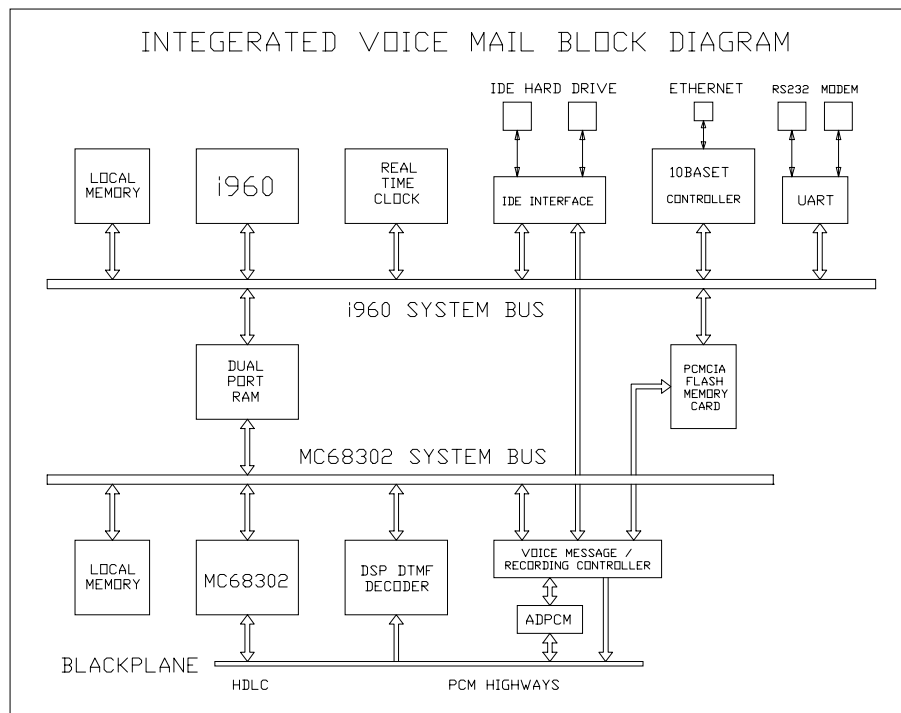

IVM Block Diagram

ASYNCHRONOUS SERIAL PORTS (Quad UART)

The IVM provides one serial interface for external connections. PORT 1 is configured to RS232C interface. Port 4 is used by the on board modem module (CH1794). The serial interfaces are supported by Philips Semiconductors SC28C94 Quad Universal Asynchronous Receiver/Transmitter (QUART). The QUART provides parallel to serial conversion, and the MODEM module interface. All four serial interfaces consists of two data and two control lines: Receive Data (RxD), Transmit Data (TxD), Request to Send (RTS), and Clear to Send (CTS). Serial data is sent over data input / output pins, RxD and TxD. The handshaking controls, RTS and CTS, are accessible in QUART control and status registers respectively.

Port 4 is used for the modem module, since the modem module provides RS232 serial interface only (TTL signal level). Two data and six control signals are used by modem. These signals are TxD, RxD, RTS, CTS, DTR (Data Terminal Ready), DCD (Data Carrier Detect), and RI (Ring Indicator).

The QUART can be programmed to generate an interrupt (QART_IRQ) to the i960 when it requires service such as FIFO empty and the modem status request. It connects to the I960 memory mapped I/O bus (8-bit) in the range of 3FFF 0400H to 3FFF 04FFH. It will generate the Data Acknowledge (QART_DT) signal to the i960 after each CPU R/W access.

Modem Features

- CCITT V.34bis, V.34 V.FC, V.32bis, V.32, V.22bis, V.22A/B, V.23, V.21
- Bell 212A and 103
- Enhanced AT commands
- S-Register Settings
- Error correction – V.42 LAMPS, MNP 2-4 and NMP 10
- Data compression – V.42bis and NMP5
- DTE interface with speed up to 57.6 Kbps
- Automated baud rate adaptability utilising speed sensing, flow control, and data buffers

IDE Interface

The IVM will support two standard ATA IDE (Integrated Drive Electronics) Hard Drives which are used on the PCs. The Hard drive is only used for Voice Mail message storage. When the Voice Mail feature is not used, the hard disk is not needed. The second drive is for data backup purpose.

The hard disk access should use LBA (Logical Block Address) instead of using CHS (Cylinder Head Sector) method. The LBA provides relatively simple and easy for software implementation. The LBA is accessing by dividing the total capacity of the hard drive into 512 byte block each. Each logical block is directly mapped into the 28-bit linear address space (137 GB max). The CPU side will see the hard drive as a large virtual memory array but each address access is fixed at 512 bytes.

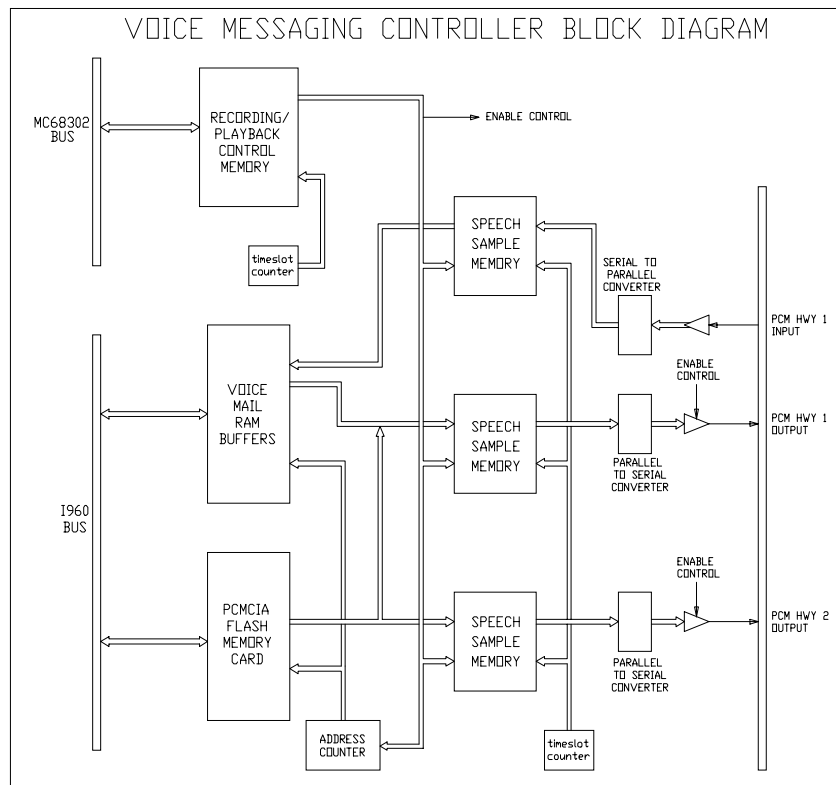

Figure 5.0 Voice Messaging Controller Block Diagram

Appendix D

TX-2400S

Automatic Call Distribution

A.C.D

Application Note

Introduction

Automatic Call Distribution (ACD) offers uniform call distribution of incoming calls to a group of station users. A group (referred to as a hunting group) is reached by dialing one master hunting directory number. The calls can be distributed using several different methods of hunting for a free member.

Incoming trunks can first be routed to a prerecorded announcement and then directed to a hunting group to ring one of free agents. If all the agents are busy the call can automatically be camped on to the hunting group to wait for a free agent. Please refer to Automatic Announcement for Incoming Trunks Application Note for more details.

Statistics on hunting group members (sometimes referred to as agents), the number of busy calls in a group, the number of calls waiting to be answered, the time to answer calls, etc. can be kept on a PC based terminal attached to a serial port on the Infinity system.

Programming

Each hunting group must have a master directory number by which the group is called. The master directory number is defined using the CHM command (see the STUG manual for details). This command is also used to define the type of hunting for a particular group.

Conditions:

- 64 Hunting Groups
- Calls made directly to hunting group members will not affect the established hunting sequences.
- Hunt Group Master Numbers must be associated with unequipped ports.
- Hunting bypass stations in Call Forward and DND.

Setup

Setup of Call Accounting Software on PC

The ACD software allows monitoring of incoming calls to the hunting groups. Current traffic status and the statistics reports for groups, agents, hunting group member phones can be generated.

The ACD software is a part of Call Accounting Software (CAS) which runs on PC Windows 95 or higher.

The Call Accounting Software should be install on a PC from the CD provided using the setup program.

Connect the PC COM2 serial port to an SMDR port of Infinity switch using speed 9600 baud. The PC can also be connected to a serial interface on an ISDN phone.

If the PC is connected to the SMDR port the SCU OPTION 1 or 2 and 5,6 should be enabled in CSC command. If the PC is connected to R interface on the ISDN phone the OPTION1 should be set to 8 by CPD command.

Follow the menu on the PC to use the ACD software package.

Setup of Music Source

The incoming caller can be connected to a music source when all the agents are busy. External music source must be provided to the system as follows:

The music source on Infinity M or L connects to P1-25 and P1-50.

On Infinity S the music sources connect MUS 2 connectors at the back of the cabinet.

See *Music on Hold Application Notes* for more details.

Related Documents

Service Terminal Users Guide (STUG)
Announcement for Incoming Trunks Application Note
Message Recording Device Application Note
Music on Hold Application Note